

GENERAL EXPERIMENTAL TECHNIQUES

Continuously Wavelength Tuned Optical Parametric Oscillator Based on Fan-out Periodically Poled Lithium Niobate

D. B. Kolker^{a, b, c}, A. A. Boyko^{a, c}, N. Yu. Dukhovnikova^{a, c}, K. G. Zenov^a, I. V. Sherstov^{a, b},
M. K. Starikova^a, I. B. Miroshnichenko^{a, c}, M. B. Miroshnichenko^a, D. A. Kashtanov^a,
I. B. Kuznetsova^a, M. Yu. Shtyrov^a, S. Zachariadis^d, A. I. Karapuzikov^a,
A. A. Karapuzikov^a, and V. N. Lokonov^b

^a Special Technologies Ltd., ul. Zelenaya gorka 1/3, Novosibirsk, 630060 Russia

^b OAO OKTAVA, Krasnyi pr. 220, Novosibirsk, 630049 Russia

^c Novosibirsk State Technical University, pr. K. Marksa 20, Novosibirsk, 630092 Russia

^d Hochschule RheinMain University of Applied Sciences,
Kurt-Schumacher-Ring 18, Wiesbaden, 65197 Germany

Received April 26, 2013; in final form, June 25, 2013

Abstract—A PC-controlled optical parametric oscillator (OPO) based on fan-out periodically poled lithium niobate (MgO : PPLN) structures was developed. Continuous wavelength tuning (2.40–3.85 μm) was realized via linear displacements of fan-out MgO : PPLN structures using a PC-controlled precision motorized translation stage. The total wavelength scanning time in the range of 2.40–3.85 μm was ≤ 1 min. The OPO was developed as a source of tunable radiation for use in a laser photo-acoustic gas analyzer. Studies of the methane absorption spectrum showed a good coincidence of the experimental and theoretical data.

DOI: 10.1134/S0020441214010217

INTRODUCTION

Measurements of trace gas concentrations in exhaled air are of great interest for clinical diagnostic studies at medical institutions [1, 2]. At present, various devices intended for analyzing exhaled air are being widely developed [3–6]. Human exhaled air is a complex gas mixture of different chemical compounds, such as CH_4 , C_2H_6 , C_2H_4 , CO , NO , H_2O_2 , CO_2 isotopes, etc. [3, 4]. Some absorption lines of these compounds are present to the maximum degree in the mid-IR wavelength range between 2 and 12 μm . Registering and measuring of the concentrations of the aforementioned trace gas in an exhaled air could provide valuable information for diagnosing physiological and biochemical processes in a human organism during certain diseases [1–4].

When developing laser gas analysis devices, it is necessary to provide the possibility of continuously tuning the radiation wavelength in the spectral range of 2–12 μm within a short time of 1–2 min. An optical parametric oscillator (OPO) meets these requirements. Periodically poled structures on the basis of lithium niobate (PPLN) are widely used to create continuously tunable OPOs in the 2.5–4.5 μm spectral range. These structures have a number of additional advantages over other nonlinear crystals in this spectral range [7].

There are two configurations of PPLN structures: with a constant period (a multigrating PPLN struc-

ture) [8] and a varying period (a fan-out PPLN structure) [5, 9, 10]. The radiation wavelength tuning in constant-period structures is performed by switching crystal sections with different periods of the structure and smoothly changing the crystal temperature, thus preventing rapid wavelength tuning [11]. The use of fan-out PPLN structures in an OPO provides continuous wavelength tuning at a constant temperature via precision linear transverse movement of the structure relative to the pump beam [5, 12].

This work was aimed at the development and study of a PC-controlled OPO based on fan-out MgO : PPLN structures with continuous wavelength tuning for use in a laser photo-acoustic gas analyzer for medical applications.

EXPERIMENTAL SETUP

The optical diagram of the experimental setup for studying the OPO based on fan-out PPLN structures is shown in Fig. 1. This setup consists of the following elements: a pumping Nd : YLF laser, a Faraday isolator *FI*, a half-wave plate $\lambda/2$, mirrors M_1 – M_6 , a lens L_1 , a pyroelectric detector *PD*, a wavelength meter *WM*, a photo-acoustic detector *PAD*, and a computer *PC*.

The pump source is a diode-pumped Q-switched Nd : YLF laser (DTL-429QT, Laser-compact Group, Russia) that operated in a pulse-repetition mode. The pump wavelength was 1.053 μm , and the pulse dura-

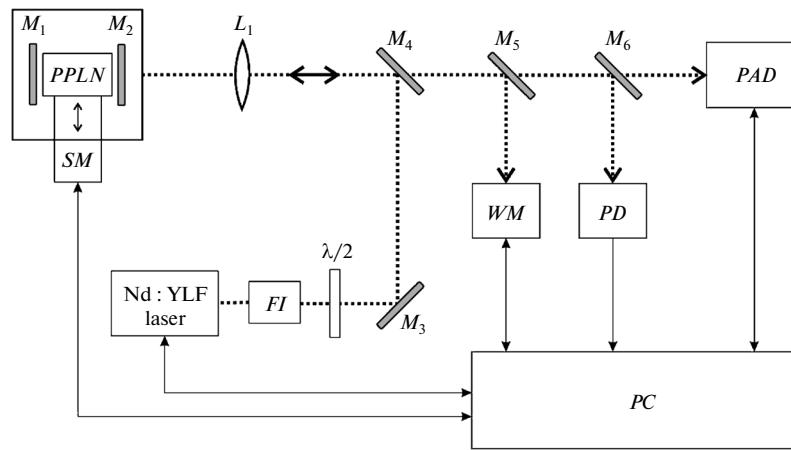

Fig. 1. Schematic diagram of the experimental setup: (*FI*) Faraday (optical) isolator; ($\lambda/2$) half-wave plate; (M_1 – M_6) mirrors; (L_1) lens; (*SM*) stepping motor; (*WM*) wavelength meter; (*PD*) pyroelectric photodetector; (*PAD*) photoacoustic detector; (*PC*) computer.

tion was 5–10 ns. The maximum laser pulse energy at a repetition rate of 100–5000 Hz was ~ 500 μ J.

Pumping radiation pulses that passed through the Faraday isolator *FI* and half-wave plate ($\lambda/2$) were reflected by mirrors M_3 and M_4 and then were focused by lens L_1 into the OPO cavity, which was formed by mirrors M_1 , and M_2 .

Two fan-out PPLN structures (Crystal Technology, USA) were used in the OPO. The topology of these structures is shown in Fig. 2. The grating periods of the first and second structures smoothly varied from 30.6 to 30.2 μ m and from 28.50 to 30.15 μ m, respectively. The dimensions of both structures were 50 \times 11 \times 1 mm.

As a result of the nonlinear conversion of pump laser pulses in fan-out PPLN structures, radiation that could be tuned in spectral ranges of 1.45–1.88 μ m (signal wave) and 2.40–3.85 μ m (idler wave) was extracted from the OPO through mirror M_2 . Subsequently, OPO radiation passed through the dichroic mirror M_4 , splitting mirrors M_5 and M_6 , and then arrived at the *PAD*, which was described in [13, 14]. The latter was used to record the absorption spectra of various gas mixtures.

Radiation of the OPO signal wave was reflected by the dichroic mirror M_5 to the wavelength meter *WM* (Angstrom LSAL IR, Russia), and M_5 was transparent for the idler. The signal wavelength was measured by the *WM*, and then the idler wavelength was determined via recalculation.

The splitter M_6 reflected a part of the idler beam to the pyroelectric detector *PD* (MG-32, Russia), which was used to measure the OPO power and normalize the *PAD* signals.

Electrical signals from the *WM*, *PD*, and *PAD* were sent to the *PC* for processing and displaying. The pulse repetition frequency, pump laser pulse energy, temper-

ature of the structures, and movement of the motorized OPO stage (for wavelength tuning) were controlled by the *PC*.

OPTICAL PARAMETRIC OSCILLATOR

An original design of the cavity (Fig. 3) was developed for the OPO. The OPO case with dimensions of 100 \times 80 \times 70 mm was made as a monolithic block of an aluminum alloy to provide high stiffness and passive stability.

The OPO cavity with a length of 58 mm is formed by the semitransparent M_2 (Layertec 105804) and reflecting M_1 (silver-coated Thorlabs ME05-P01) plane mirrors.

Fan-out MgO : PPLN structures were placed on the optical axis of the OPO cavity inside a thermostat. A Peltier element was used to maintain the optimal temperature of both structures at a level of 40–130°C with an accuracy of $\leq \pm 0.1^\circ\text{C}$. The OPO radiation-wavelength tuning was performed via precision transverse displacements of the fan-out MgO : PPLN structures relative to the optical cavity axis using the 8MT173-20-E4 motorized linear translation stage

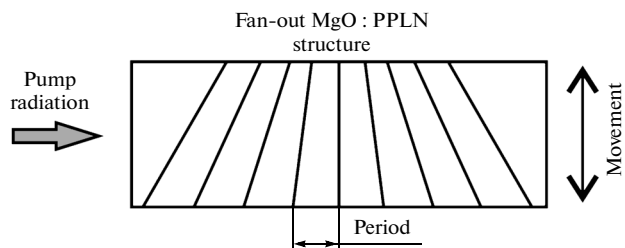

Fig. 2. Topology of the fan-out PPLN structure.

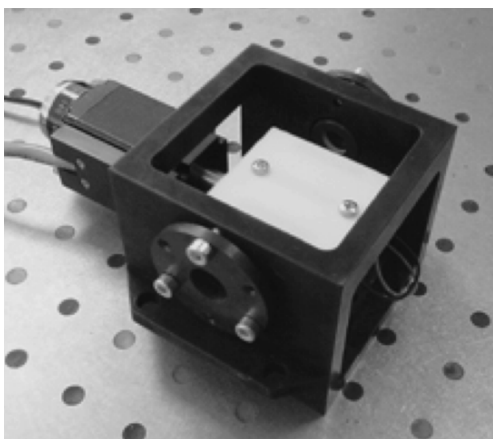

Fig. 3. Appearance of the OPO cavity.

(Standa, Lithuania). The latter was driven by a stepper motor *SM*. The motorized translation stage and the temperature of structures were controlled by the PC.

Figure 4 shows the experimental dependence of the idler wavelength versus the motorized translation stage displacement (number of stepper motor steps from the initial position) at a structures temperature of 100°C.

The translation-stage linear displacement pitch was 1.25 μm , thus resulting in the OPO frequency tuning by $\sim 0.1 \text{ cm}^{-1}$ at a wavelength of 3 μm . The analysis of Fig. 4 shows that the OPO spectral characteristic consists of two parts that correspond to different fan-out PPLN structures. The obtained idler wavelength tunability was 2.40–3.1 μm for the first structure and 3.30–3.85 μm for the second structure. The total scan time in a spectral range of 2.4–3.85 μm was about ≤ 1 min. The OPO tuning discontinuity was caused by a specific feature of the used structures—the struc-

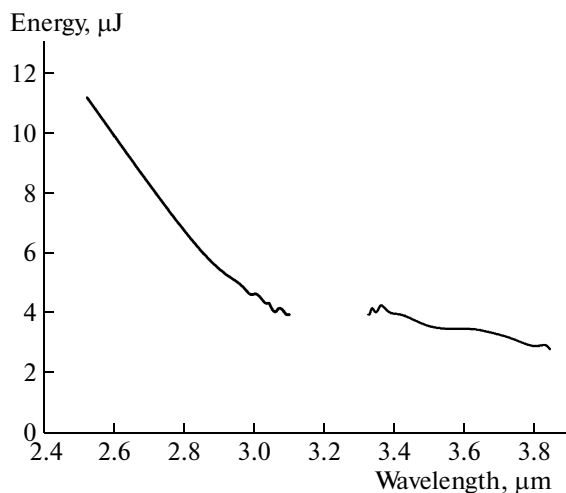

Fig. 5. OPO pulse energy versus the idler radiation wavelength (experiment).

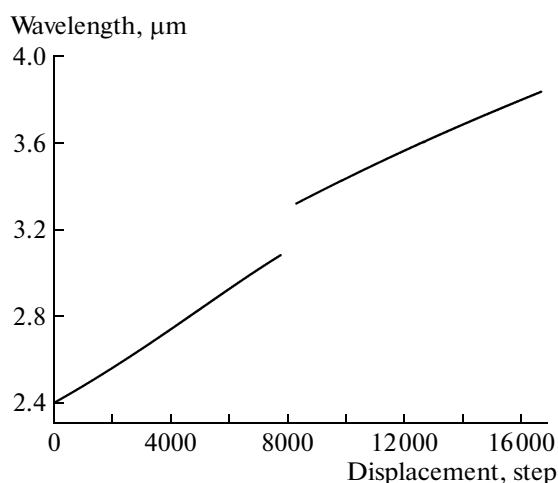

Fig. 4. Experimental dependence of the OPO idler wavelength on the position of the motorized translation stage (number of stepper-motor steps from the initial position).

tures had no spectral overlapping at the same temperature.

Note that the idler wavelength tuning range shifted towards shorter wavelengths and was 2.35–3.05 μm for the first and 3.25–3.83 μm for the second structure by increasing their temperature to 129°C. Thus, changing the working temperature of the structures allows shifting the wavelength tuning range in the tuning characteristics of both structures.

Figure 5 shows the experimental dependence of the OPO pulse energy of the idler wave on the wavelength in the spectral range of 2.40–3.85 μm . The experi-

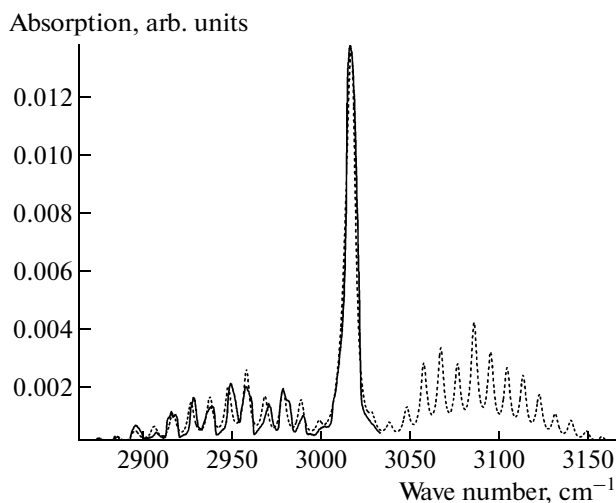

Fig. 6. Absorption spectrum of methane (gas mixture of 0.1% CH_4 in nitrogen): (solid line) experiment and (dashed line) simulated spectrum from the HITRAN database.

ments were carried out under the following conditions: pump laser pulse energy was 144 μJ ; the pulse repetition frequency, 1700 Hz; and the temperature of the PPLN structures, 101°C. The OPO pulse energy was measured using an OphirVega PE-10C power/energy meter (Israel) placed in front of the mirror M_6 .

As is shown in Fig. 5, the maximum idler-wave pulse energy ($\sim 12 \mu\text{J}$) was observed near a wavelength of 2.4 μm . The average OPO radiation power was $\sim 20 \text{ mW}$ (1700 Hz) at 2.5 μm . The OPO energy monotonically decreased with increasing the wavelength in a spectral range of 2.40–3.85 μm . This is due to an increase in the absorption level in lithium niobate at wavelengths $> 3.5 \mu\text{m}$. The OPO lasing threshold was 10–16 mJ/cm^2 in a range of 2.40–3.85 μm .

ANALYSIS OF THE CH_4 ABSORPTION SPECTRUM

The absorption spectrum of methane (CH_4) was studied using the experimental setup described above. As is known, methane has strong absorption lines centered at 3.3 and 7.5 μm [15]. The spectral range from 3.25 to 3.45 μm (3200–2900 cm^{-1}) was chosen for recording the methane absorption spectrum. In this experiment, the temperature of the fan-out PPLN structures in the OPO was 116°C. A test gas mixture containing 0.1% methane in nitrogen was used.

The PAD that was used in this study was 90 mm in length and had a fundamental resonance frequency of $\sim 1700 \text{ Hz}$, and the quality factor was ~ 40 [13, 14]. The PAD was filled with the test gas mixture via the gas purging. The pulse repetition frequency of the pump laser was equal to the PAD resonance frequency. The OPO wavelength was continuously tuned in a spectral range of 3.25–3.45 μm (3077–2899 cm^{-1}), the tuning speed was $\sim 10 \text{ cm}^{-1}/\text{s}$. The methane absorption spectrum was measured with the PAD. Data from the PD were used to normalize the PAD signals with respect to the OPO radiation power. The normalized absorption spectrum of methane was recorded by the PC in real time.

The experimental and calculated absorption spectra of methane around a frequency of 3030 cm^{-1} (3.3- μm wavelength) are shown in Fig. 6. The calculated spectrum of methane was plotted using the HITRAN database [15] with consideration for the spectral linewidth (3–5 cm^{-1}) of the OPO radiation. As is seen in Fig. 6, the experimental and calculated absorption spectra of methane almost coincide, thus confirming a high degree of reliability of the obtained results.

CONCLUSIONS

The PC-controlled developed OPO provides continuous wavelength tuning in a spectral range of 2.40–3.85 μm . Fan-out MgO : PPLN structures were used

in the OPO. The wavelength tuning was performed via precision linear movements of the structures.

The absorption spectrum of methane was investigated using the designed OPO. The experiments showed the high degree of reliability of the obtained results. A prototype of a laser gas analyzer based on an OPO and a PAD was developed for recording the absorption spectra of different gaseous substances. This system can be used for industrial, medical, and special applications.

ACKNOWLEDGMENTS

This study was supported by the Federal Target Program “Human Capital for Science and Education in Innovative Russia” for 2009–2013, contract no. 16.522.11.2001.

REFERENCES

1. Ageev, B.G., Kistenev, Yu.V., Nekrasov, O.Yu., Niki-forova, O.Yu., Nikotin, E.S., Nikotina, G.S., Ponomarev, Yu.N., Urazova, O.I., Filinyuk, O.V., Fokin, V.A., and Yanova, G.V., *Byull. Sibir. Med.*, 2012, vol. 11, no. 4, p. 116.
2. Chuikova, K.I., Kistenev, K.I., and Gomboeva, S.S., *Byull. Sibir. Med.*, 2012, vol. 11, no. 6, p. 178.
3. Stepanov, E.V., in *Lazernyi spectral'nyi analiz molekulyarnykh biomarkerov dlya meditsinskoi diagnostiki. Trudy instituta obshchei fiziki* (Laser-Based Spectroscopy Analysis of Molecules Biomarkers for Biomedical Diagnostics. Proc. Gener. Phys. Inst.), Stepanov, E.V., Ed., Moscow: Nauka, 2005, vol. 61, p. 5.
4. Bingi, V.N., Stepanov, E.V., Chuchalin, A.G., Milyaev, V.A., Moskalenko, K.L., Shulagin, Yu.A., and Yangurazova, L.R., in *Lazernyi spectral'nyi analiz molekulyarnykh biomarkerov dlya meditsinskoi diagnostiki. Trudy instituta obshchei fiziki* (Laser-Based Spectroscopy Analysis of Molecules Biomarkers for Biomedical Diagnostics. Proc. Gener. Phys. Inst.), Stepanov, E.V., Ed., Moscow: Nauka, 2005, vol. 61, p. 189.
5. Van Herpen, M.M.J.W., Li, S., Bisson, S.E., Hekker, S.T.L., and Harren, F.J.M., *Appl. Phys. B*, 2002, vol. 75, nos. 2–3, p. 329.
6. Miklos, A., Lim, C.-H., Hsiang, W.-W., Liang, G.-C., Kung, A. H., Schmohl, A., and Hess, P., *Appl. Opt.*, 2002, vol. 41, no. 15, p. 2985.
7. Sorokina I.T. and Vodopyanov, K.L., in *Solid-State Mid-IR Laser Sources. Topics Appl. Phys.*, Sorokina, I.T. and Vodopyanov, K.L., Eds., Berlin: Springer-Verlag, 2003, vol. 89, p. 141.
8. Myers, L.E., Eckardt, R.C., Fejer, M.M., and Byer, R.L., *J. Opt. Soc. Am.*, 1995, vol. 20, no. 12, p. 2102.
9. Adler, F., Cossel, K.C., Thorpe, M.J., Hartl, I., Fermann, M.E., and Ye, J., *Opt. Lett.*, 2009, vol. 34, no. 9, p. 1330.
10. Nelet, A., Jonusauskas, G., Degert, J., and Freysz, E., *Proc. Conf. on Lasers and Electro-Optics (CLEO 2007)*, Baltimore, 2007, p. 2.

11. Kolker, D.B., Pustovalova, R.V., Starikova, M.K., Karapuzikov, A.I., Karapuzikov, A.A., Kuznetsov, O.M., and Kistenev, Yu.V., *Instrum. Exp. Tech.*, 2012, vol. 24, no. 2, p. 263.
12. Gorelik, P.V., Wong, F.N., Kolker, D.B., and Zondy, J.-J., *Opt. Lett.*, 2006, vol. 31, no. 13, p. 2039.
13. Lee, C.-M., Bychkov, K.V., Karapuzikov, A.I., Sherstov, I.V., Vasiliev, V.A., Kapitanov, V.A., and Ponomarev, Y.N., *Opt. Eng.*, 2007, vol. 46, no. 6, p. 64302.
14. Karapuzikov, A.I., Sherstov, I.V., Ageev, B.G., Kapitanov, V.A., and Ponomarev, Yu.N., *Opt. Atmos. Okeana*, 2007, vol. 20, no. 5, p. 453.
15. Rothman, L.S., Jacquemart, D., Barbe, A., Chris Benner, D., Birk, M., Brown, L.R., Carleer, M.R., Chackerian, Jr., C., Chance, K., Coudert, L.H., Dana, V., Devi, V.M., Flaud, J.-M., Gamache, R.R., Goldman, A., Hartmann, J.-M., Jucks, K.W., Maki, A.G., Mandin, J.-Y., Massie, S.T., Orphal, J., Perrin, A., Rinsland, C.P., Smith, M.A.H., Tennyson, J., Tolchenov, R.N., Toth, R.A., Vander Auwera, J., Varanasi, P., and Wagner, G., *J. Quant. Spectrosc. Radiat. Transfer*, 2005, vol. 96, no. 2, p.139.

Translated by A. Seferov